

OLYMPUS

Your Vision, Our Future

Digital Imaging Solutions

cell[™]/cell[®]

cell* Family

The Next Level in Live Cell Imaging



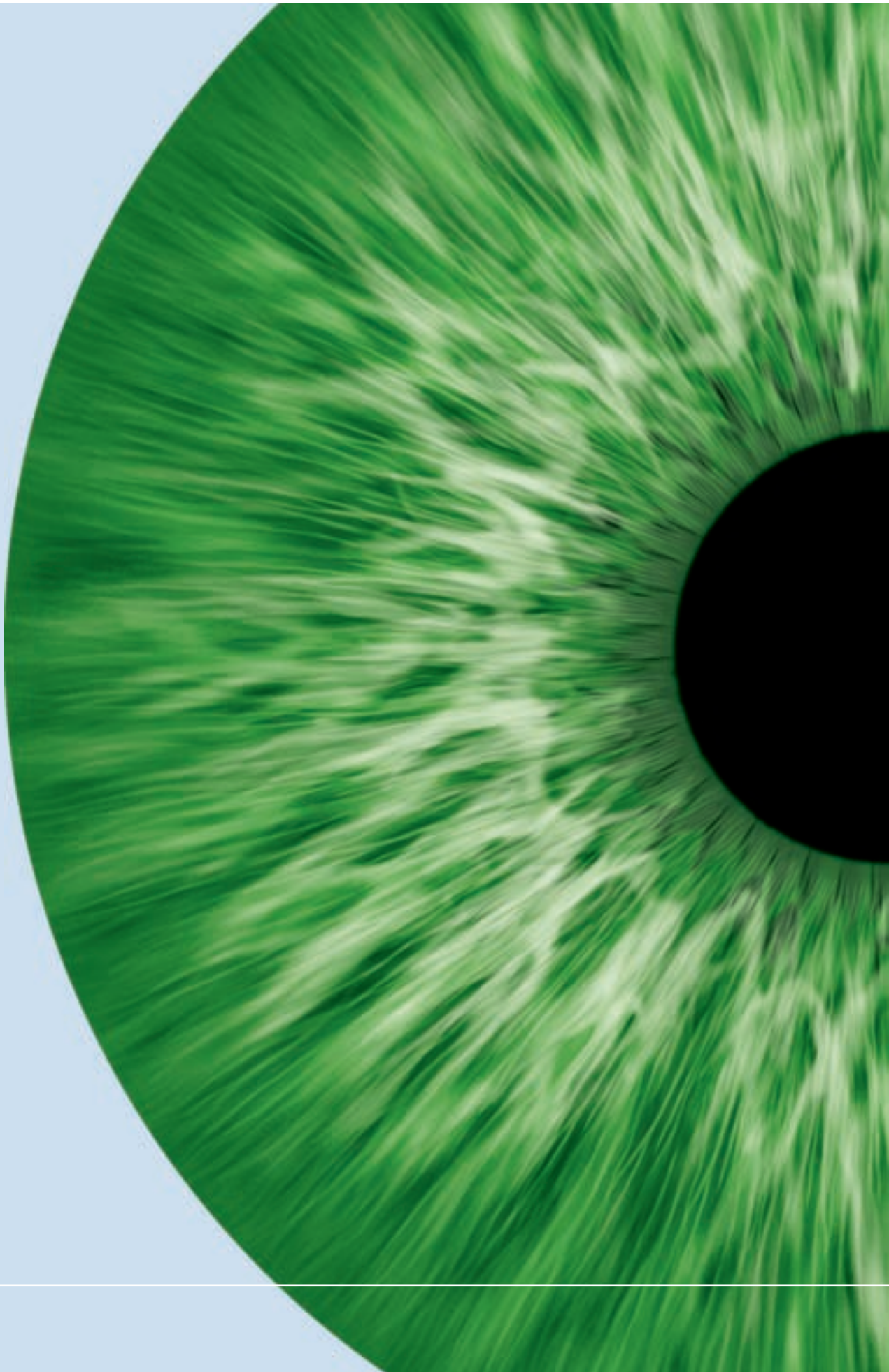

LOOKING BEYOND THE IMAGE

Dynamic processes and structural characterisation in living cells

cell^M and cell^R are members of the Olympus cell* family, designed for the advanced demands of live cell imaging. They are modular imaging stations that support the IX2 and BX2 series of Olympus microscopes. Their unique all-in-one Illumination Systems – MT10 and MT20 – respectively, allow fast wavelength switching and attenuation, having been specially designed to meet the experimental requirements for rapid image acquisition using highly sensitive digital cameras for a broad range of life science experiments. cell^M is designed to capture fast events and cell^R has been optimised to image very fast processes in living cells, operating at about twice the speed of cell^M. cell^R achieves this by incorporating a special control board, which synchronises all hardware modules including optional peripheral devices. It is functionally independent of the imaging computer, which ensures the highest accuracy in experiment timing.

The user-friendly software for both imaging stations is powerful and all-encompassing. It features an intuitive, graphical drag-and-drop interface, the easy to use 'Experiment Manager', to set up even the most complex experiments in a convenient and concise way.

INSIGHTS INTO THE SECRETS OF LIFE

Advanced applications in live cell imaging

Microscopy in bioscience has progressed from the purely structural characterisation of fixed cells towards the investigation of processes in living cells with recent advances in fluorescence technology. Static morphological observation can now be complemented by the characterisation of the 3-D architecture of cellular structures and the real-time investigation of dynamic molecular processes in living cells. Newly developed fluorescence methods such as TIRF and FRET microscopy or GFP labelling are pushing the frontiers and widening the scope of bio-imaging.

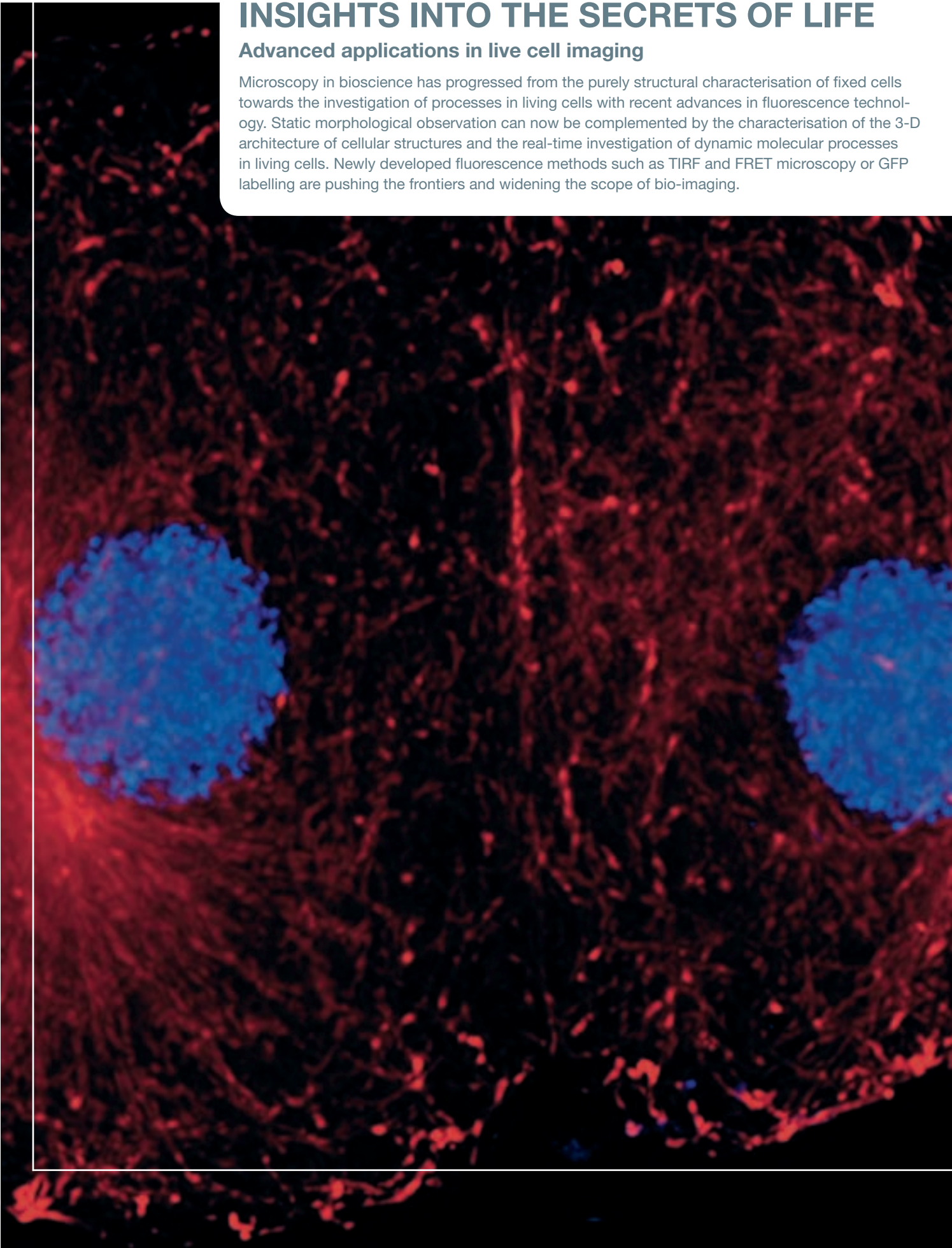

Time-lapse Imaging

Dynamic processes such as cell growth, metabolic transport and signal transduction are monitored routinely nowadays. The duration of such processes may vary from the sub-second range to hours or even days. Consequently it may be necessary to take several images per second or just one image every couple of minutes.

Multi-colour and GFP Imaging

The development of a growing list of specific fluorochromes covering the entire colour range enables the scientist to image and distinguish different sub-cellular structures simultaneously within one experiment through the use of multiple staining. If this is combined with time-lapse acquisition, the illumination unit of the microscope must be able to switch quickly between excitation wavelengths.

Z-sectioning and Multi-dimensional Imaging

Microscopy is basically a two-dimensional observation technique while biological samples are three-dimensional. Therefore, in order to map the entire volume of the specimen, it can be imaged in layers by moving the focal plane in precise steps using a motorised Z-drive or a piezo-electric objective drive.

Ion Imaging / Ratio Imaging / Ca⁺⁺ Imaging

The fluorescence behaviour of several dyes is dependent on the concentration of certain ions such as calcium (Fura-2) or on the pH value (BCECF). The detection, quantification and analysis of changes in fluorescence intensity are thus an indirect means to study important physiological processes.

FRET (Foerster Resonance Energy Transfer)

The measurement of fluorescence energy transfer from a fluorochrome molecule to an adjacent one can be used for the investigation of molecular interactions in cells. It requires the acquisition of images with different excitation and emission wavelengths and sophisticated correction algorithms.

TIRFM (Total Internal Reflection Fluorescence Microscopy)

Investigating surfaces without interference from background light can be carried out using Total Internal Reflection Fluorescence Microscopy. Laser light coupled together with the standard fluorescence excitation allows fast switching between TIRF and wide-field fluorescence applications and can even support simultaneous observation.

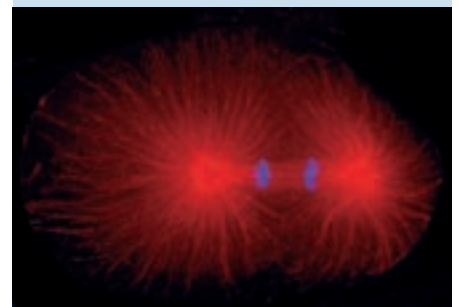
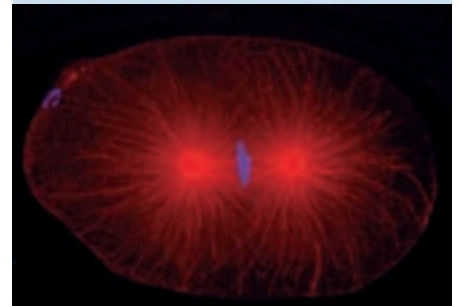
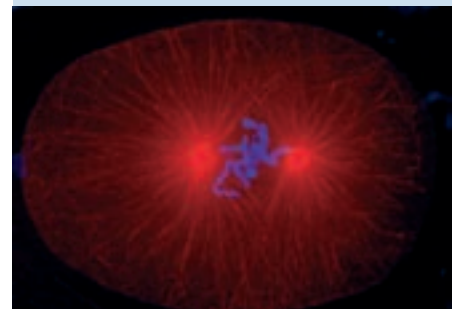
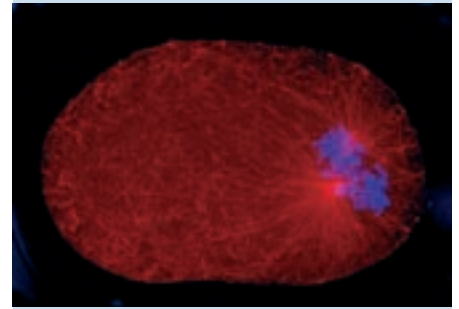

Cell division in the early *C. elegans* embryo, microtubules in red, DNA in blue. Courtesy of K. Oegema, T. Hyman group, Max-Planck Institut, Dresden, Germany.

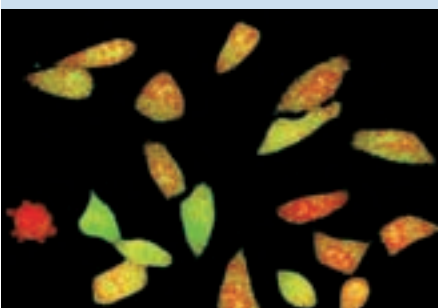
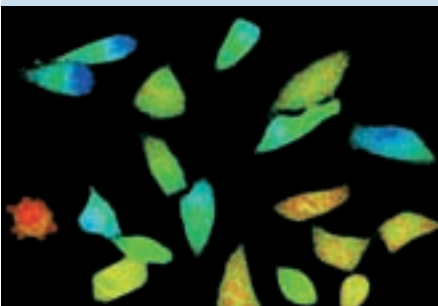
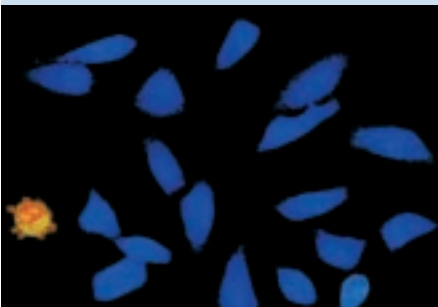
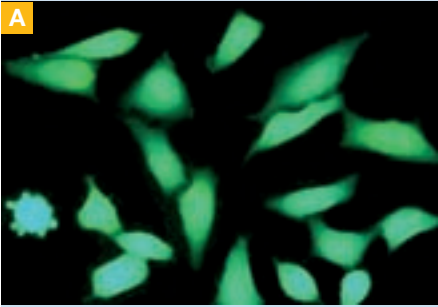

Time-lapse imaging:
Fura2-labelled HeLa cells stimulated
with ATP. Top: dual-excitation image;
below: false-colour ratio images reveal-
ing increasing calcium concentration.

cell^M AND cell^R – INTUITIVE IMAGING SOFTWARE

The powerful software enables remote control of all attached devices and user-definable database storage to archive the multi-dimensional data sets (XYZ, time, colour and stage position). This archive also stores the range of analysis and report files generated by the comprehensive processing tools, allowing full traceability of raw and derived data.

cell^M and cell^R hardware integration

Microscope and device control

cell^M and cell^R fully control all motorised modules of the Olympus IX2 and BX2 series microscopes. Additionally, motorised stages, piezo-electric objective and nosepiece drives, as well as light management equipment, such as filter wheels and shutters, can all be integrated into the imaging stations. A trigger interface (integral for cell^R and optional for cell^M) allows synchronisation of up to three peripheral devices via TTL pulses with the experiment flow.

Camera control

Various monochrome CCD and intensifying EMCCD, as well as colour cameras are supported by cell^M and cell^R and are synchronised with the sample illumination units. Imaging speed can be increased by pixel-binning and reducing the read-out area by selecting regions of interest.

The Experiment Manager: universal planning and execution tool

cell^M and cell^R are multi-device imaging stations designed to carry out even the most complex tasks. This requires an efficient interplay between all components of the system, which is achieved via a unique graphical user interface. Experiments can be set up and parameterised by intuitive drag-and-drop assembly of command icons — such as “image acquisition”, “z-stack” or “time loop”. This simple procedure creates the control code for the whole series of hardware actions required, meaning the user does not have to consider these in detail. Simple tasks such as a time series of monochrome images can be easily defined, as well as the most complex data acquisitions requiring multi-device systems, including motorised microscopes and automated components. The complete experiment plan is visible at a glance and is stored with the data in the archival database. The design concept is very intuitive and self-explanatory to minimise training requirements — an ideal solution for multi-user environments and imaging facilities.

Example experiment plan for dual-colour z-stack acquisitions at different stage positions with autofocus, repeated over time.

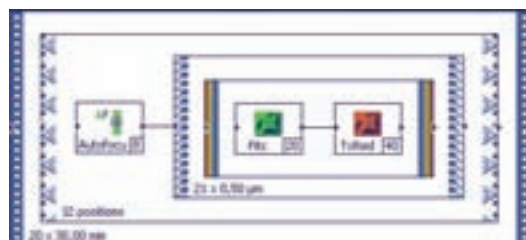

All that is needed to define this complex experiment: three icons (for autofocus and image acquisitions) and four frames (for fluorescence overlay, z-stack acquisition, stage positions and time-lapse repetition).

Basic cell^M and cell^R software features

Archiving

The integrated database archives multi-dimensional image series along with analytical data, reports and associated documents in a well-structured system. The database has been designed to make access fast and navigation easy, while keeping network capacity requirements low.

Measurements

cell^M and cell^R feature a unique measurement environment suitable for interactive measurement tasks and dimension calculations. Results can be presented as graphs or sheets and evaluated directly to determine mean values, extremes and standard deviation.

Image processing and 3-D visualisation

cell^M and cell^R provide a host of processing functions such as background subtraction, shading correction, display adjustment as well as filtering and overlay of fluorescence and transmission images. Deblurring algorithms (no neighbour, nearest neighbour and inverse filter) enhance the spatial resolution of widefield microscopy by reducing out-of-focus blur to yield images with greatly improved clarity. The SliceViewer generates slices through image stacks while the VoxelViewer renders three-dimensional images and iso-surfaces.

Report generation

The report generator makes creating reports, compliant to the various standards, quick and easy via a simple drag-and-drop process. These reports can contain graphical elements such as images, sheets and diagrams and also offer uncomplicated text input. Placeholders are automatically filled with the contents of various fields – from the archive or from analytical results.

Programming

The programming language 'Imaging C' offers advanced users a complete, integrated development environment. This includes a programming library with unrestricted access to the wide range of image acquisition and processing functions. 'Imaging C' consists of a compiler, an interpreter, a macro recorder, a multiple-document (MDI) text editor, a symbol and function browser, and an interactive debugger with single-step processing, conditional breakpoints as well as a browser for variables and constants.

Advanced analysis

Fluorescence analysis and kinetics

A More complex analysis routines required for processes such as ion imaging are included: intensity kinetics, co-localization statistics as well as ratio and $\Delta F/F$ analyses. Results are provided as false-colour images, graphs of regions of interest and data sheets.

Spectral unmixing: enhanced colour resolution

B Pronounced spectral overlap of the excitation and emission characteristics often prevents the combination of certain fluorescent markers within one sample. Linear spectral unmixing ascertains the contribution of different fluorochromes to the total signal and, by chromatic redistribution of the intensity, restores a clear signal for each colour channel, undisturbed by the emission from other fluorochromes. This procedure uses the inherent information of the data, and the results are therefore not simply embellished images. The spectral redistribution maintains the overall intensity and facilitates quantitative analyses, for example in co-localization and FRET studies.

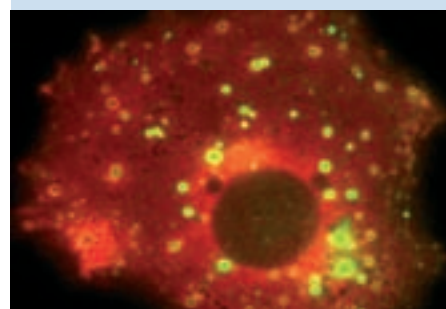
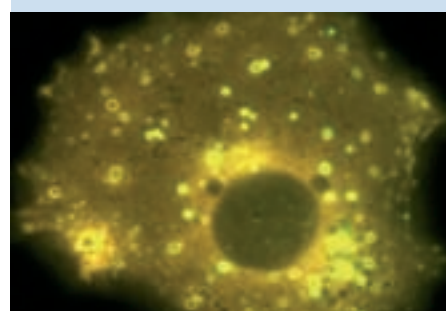
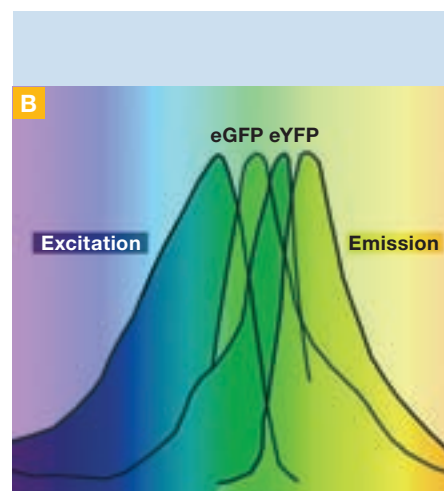

Spectral unmixing:
GFP-labelled vesicles and YFP-labelled membrane proteins; YFP displayed in red for clarity. Centre: original image; bottom: after spectral unmixing.
Courtesy of Y. Okada, Grad. School of Medicine, Univ. Tokyo, Japan.



A Highly stable light output

Comparison with standard Hg burners

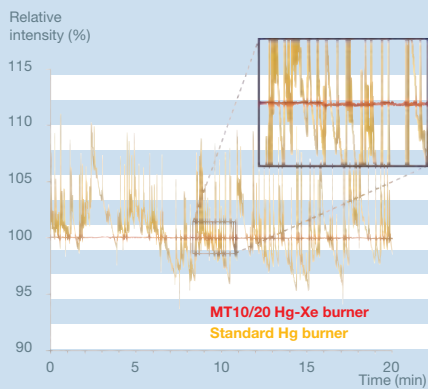

Light output normalized to the average intensity (100%).

A Burner intensities

Hg-Xe relative to normalized Xe burner intensities (100%)

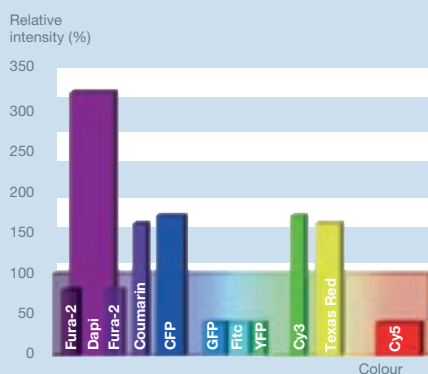

Selected Hg-Xe burner intensities (bars) compared to those of a Xe burner when using the same excitation filters (340/15, 360/40, 380/15, 403/12, 430/25, 470/20, 492/18, 510/10, 546/12, 572/23, 635/40)

ADVANCED LIGHT MANAGEMENT AND SYSTEM SYNCHRONISATION

The multi-function illumination systems MT10 and MT20

Fast switching between excitation wavelengths is crucial for many applications, e.g., dual excitation ratio measurements or fast multi-colour time-lapse experiments. The all-in-one illumination systems, MT10 and MT20, match these exacting requirements with filter switching times of 85 and 58 ms, respectively. Eight standard 25 mm filter positions are provided. A unique mechanism allows the manual replacement of filters in seconds without the need for tools.

The integrated attenuators switch between the intensity grades at even faster speeds than the filter wheel. On the MT10, seven intensity levels are provided, whereas the MT20 has 14. The built-in shutters have exceptional on/off intervals of only 1 ms for the MT 20 and less than 5 ms for the MT10, which eliminates photo-bleaching when you are not acquiring an image, a fundamental prerequisite for the imaging of living specimens.

A The user has the choice between two types of arc burners: xenon, the standard option, with a rather even output over the entire range (near-UV to near-IR) or mercury-xenon with five very intense peaks that guarantee low exposure times for samples with corresponding fluorophores. The stability of both types is much superior to that of standard Hg burners. Additionally, stabilizing electronics of MT10 and MT20 enhance the performance.

Fibre-coupled epi-fluorescence illumination

B A single-quartz fibre coupling of the light source to the microscope ensures temperature and vibration isolation for all experiments. This lack of vibration also means that there is no idle time caused usually associated with directly mounted filter wheels, therefore clear and crisp images can be acquired immediately after a filter change. The flexible guide also allows the light source to be placed outside a Faraday cage or climate chamber, producing a system compatible with patch clamp and sensitive live cell imaging experiments. Optimised epi-fluorescence illuminators ensure maximum light efficiency and homogeneity, and an integrated photodiode makes the adjustment of the burner position very easy.

Schematic array of the MT10 / MT20 modules

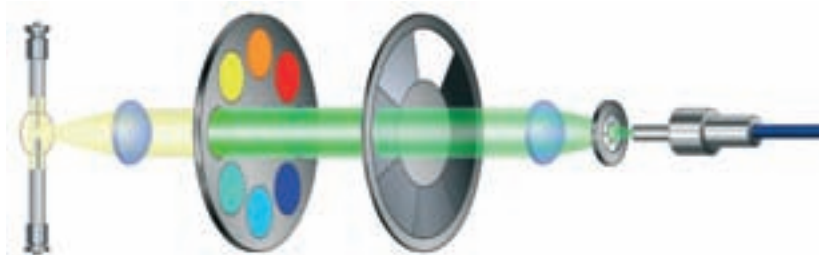

From left to right: arc burner, filter wheel, attenuator, shutter and fibre

Superior hardware control: the cell^M System Coordinator and the cell^R Real-Time Controller

Independent plug-in CPU boards for both imaging stations ensure uninterrupted data uptake by the imaging computer during experiments. Experiment control and timing precision are maintained while changing hardware settings. MT10 and MT20 filter wheels, attenuators and shutters are optimally synchronised with the camera, as well as the optional piezo z-drives and other devices. Some manufacturers rely on the imaging computer to control the hardware during image acquisition. This leads to unavoidable decreases in timing precision and a lack of consistent data transfer, thus reproducibility of experiments is more difficult to obtain. For complex multi-device experiments therefore, the cell^R Real-Time Controller runs in parallel with its main computer and provides microsecond precision as well as guaranteed hardware interplay and efficiency. This also makes cell^R about twice as fast as cell^M with its System Coordinator.

Integration of peripheral components

C An I/O panel with three BNC plugs is conveniently placed at the front of the PC (integral for cell^R and optional for cell^M) to enable easy addition and control of peripherals. Sockets are also provided for the integration of external devices such as motorised microscope controllers (UCB), motorised stages or an emission filter wheel.

Comparison of the illumination systems MT10 and MT20

MT10 and MT20	
Arc burners	150 W, optionally xenon or mercury-xenon, output stabilizing electronics
Illuminators	critical epi-illumination, intensity optimisation via integrated photodiode
Filters	8 positions, 25 mm, quick, tool-free exchange
Light fibre	2 m (optionally 3 m) single quartz

	MT10	MT20
Operation	modules sequentially	all modules in parallel
Filter switch	min. 85 ms (neighbouring positions)	min. 58 ms (neighbouring positions)
Attenuation	7 levels, < 85 ms switch	14 levels, < 58 ms switch
Shutter	< 5 ms on/off time	1 ms on/off time

Comparison of the hardware controllers

	System Coordinator	Real-Time Controller
Operation	sequentially	all components in parallel
Digital I/O panel	optional	standard
Temporal resolution	10 ms (camera 1 ms)	1 ms
Timing precision	about 15 ms	< 0.01 ms
Multi-task imaging	3-4 frames/sec @ 50 ms exposure	8 frames/sec @ 50 ms exposure

B Fibre illuminator

for critical illumination



C Peripherals integration

Trigger ports on the PC front panel



Time-lapse experiment plan with online kinetic and triggered event (for example a micro-injection)

A

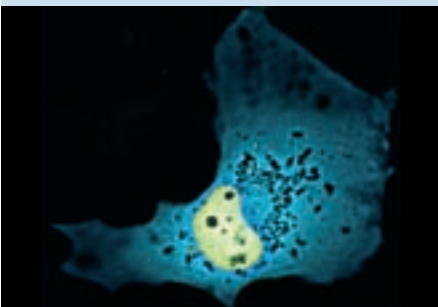
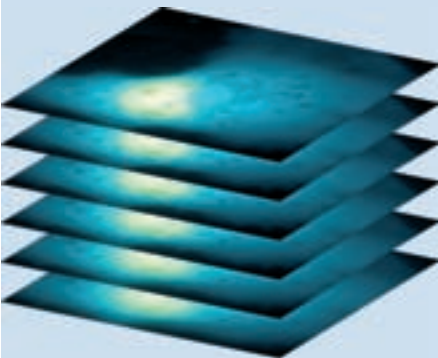
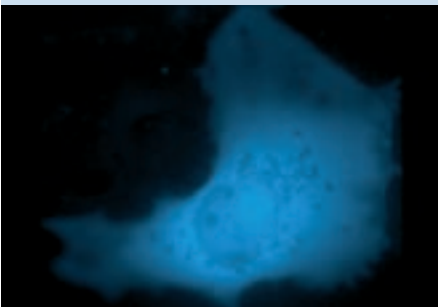
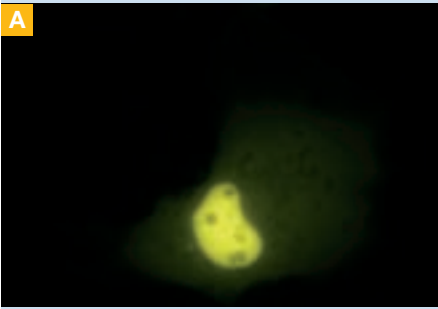

Three-dimensional imaging: COS-1 transfected with pEYFP - GRP and pECFP-GK-L58R/N204Y. Courtesy of S. Baltrusch, S. Lenzen, Inst. f. klin. Biochem., Mediz. Hochschule Hannover, Germany. From top: YFP image, CFP image, dual-coloured image stack, deconvolved image.

ADDITIONAL MODULES FOR DIFFERENT APPLICATIONS

3-D deconvolution and rendering

A Three-dimensional imaging is achieved by taking a series of images with changing focal positions using a motorised microscope Z-drive or a fast high-resolution piezoelectric objective drive. The z-stack acquisition can be complemented with 3-D rendering and deconvolution software packages for three-dimensional image generation and resolution enhancement.

trackIT!

Moving objects, e.g., vesicles or entire cells, can be detected automatically and tracked over a time-course. The results are presented as movies showing object tracks, accompanied by charts and histograms of parameters such as velocity, direction, path length and total distance.

Particle analysis

Intensity threshold-based evaluation of images provides particle detection, particle-specific measurements (area, size, shape, location, density and intensity) and evaluation of regions of interest or object classes.

TIRF

B Total Internal Reflection Fluorescence Microscopy (TIRFM) is a technique for high-resolution cell membrane and surface studies based on laser illumination and extremely high numerical aperture objectives. The TIRF upgrade permits the use of up to three lasers (five different wavelengths are available) via a multi-port illumination combiner, enabling switching between evanescent wave and widefield illumination. TIRF microscopy can therefore be used alongside standard imaging with illumination from the MT10 or MT20.

B

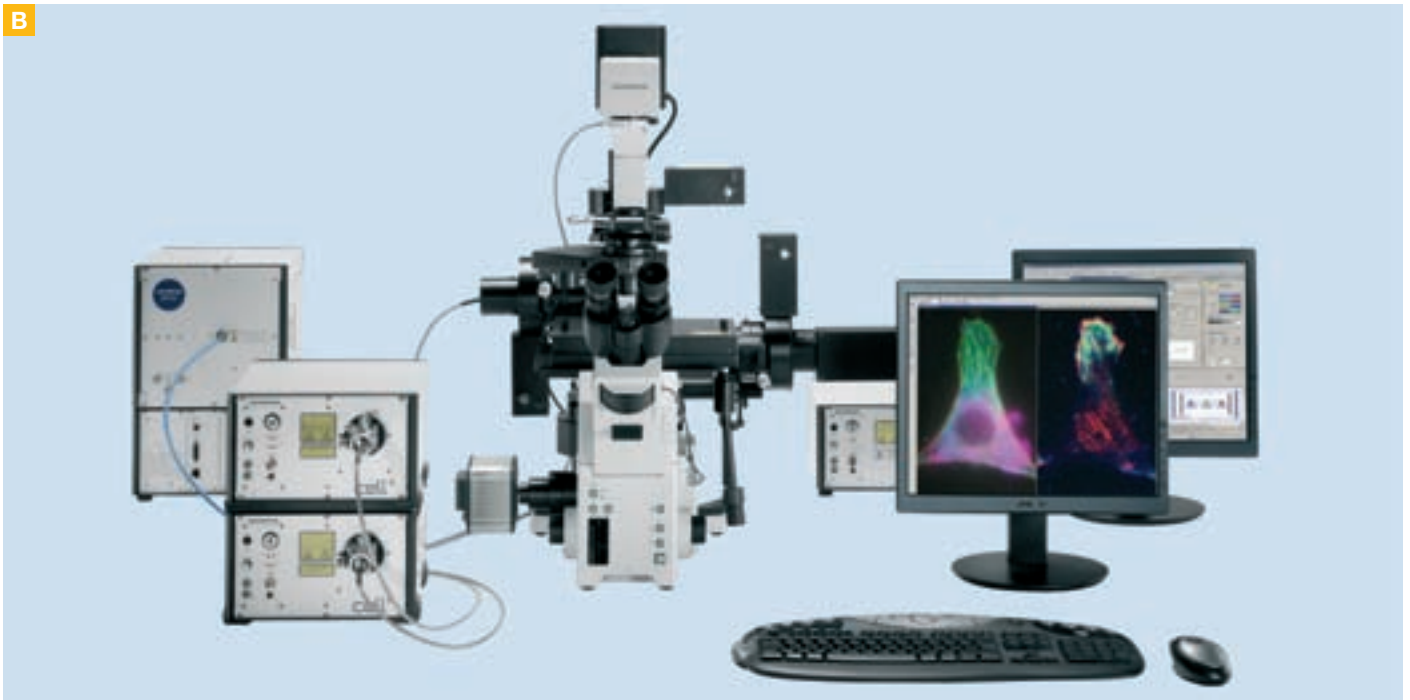

FRET

C FRET (Foerster Resonance Energy Transfer) and dual-emission ion imaging studies are based on observations at different wavelengths, which can be performed conveniently with the fast switching filter wheel U_FFOW (min. 58 ms).

D A second option is the Dual-View™ Micro-Imager beam-splitting device that allows the simultaneous acquisition of two chromatically separated fluorescence images at half the normal frame size. The FRET software add-on provides different analysis algorithms (Ratio, Youvan, Gordon and Xia). The data evaluation is facilitated by the spectral unmixing function of the standard cell^M and cell^R software packages.

Environment control

The climate chamber cell^{cubator} with anti-scratch coating, for the IX2 series inverted microscopes, keeps living specimens under optimum environmental conditions during time-lapse experiments. It regulates humidity (from ambient upwards) and CO₂ (ambient to 10%) in 2 minutes and allows for temperature settings from ambient to 42°C.

C U_FFOW

Fast observation filter wheel



D Dual-emission imaging

Beam-splitting device



Specifications

cell^M

cell^R

Hardware	cell ^M	cell ^R
Olympus microscopes BX50 - BX61, BX51WI, BX61WI, IX50 - IX81	X	X
CCD cameras: various models, typically 12 bit, IEEE.1394, 1.3 Mpixel	X	X
EMCCD cameras: various models	X	X
Imaging computer, latest generation PC	X	X

Illumination system	MT10	MT20
Short arc burners, 150 W, Xenon or Mercury-Xenon	X	X
Filter positions, diameter 25 mm	8	8
Filter switch	min. 85 ms (neighbouring positions)	min. 58 ms (neighbouring positions)
Attenuation	7 levels, 4% - 100%	14 levels, 1% - 100%
Attenuation switch	< 85 ms	< 58 ms
Shutter, on/off time	< 5 ms	1 ms
Operation	sequentially	all modules in parallel

Hardware control	cell ^M	cell ^R
Control board with additional CPU, independent from imaging PC	System Coordinator	Real-time Controller
Temporal resolution	10 ms (camera 1 ms)	1 ms
Timing precision	ca. 15 ms	< 0.01 ms
Camera control	trigger (level trigger if accepted by camera)	trigger (level trigger if accepted by camera)
Peripheral device control via TTL pulses	optional: 3 BNC connectors	3 BNC connectors
Multi-task acquisition with hardware switch (z-position, exciter filter etc.), 50 ms exposure	3-4 full frames/sec with sequential hardware switch	8 full frames/sec with parallel hardware switch

Experiment set-up and control	cell ^M	cell ^R
Graphical interface Experiment Manager	X	X
Drag-and-drop alignment of command icons	X	X
7-D acquisition (xyz, excitation and emission colour, time, stage position)	X	X
Loop-in-loop capability (repetition of complex command groups)	X	X
Experiments with varying acquisition speed and camera exposure	X	X
Autofocus, repeatedly during experiment	X	X
Live image display and online analysis	X	X
User interaction: pause, resume, set marker	X	X

Imaging software	cell ^M	cell ^R
Structured database for multi-dimensional data handling and storage	X	X
Image types: (n x 16) bit, 8 - 24 bit export and import	X	X
Image processing: filters, extended focal imaging, shading and background correction, arithmetic...	X	X
Measurements and analyses: number, length, distance, area, circumference, angle, grey value, histograms, line profiles, tables, statistics, diagrams...	X	X
Fluorescence analyses: intensity kinetics, ratioing, $\Delta F/F$	X	X
Spectral unmixing for optimised colour resolution	X	X
Deblurring, SliceViewer, VoxelViewer	X	X
Macros and automated functions: imaging C module, macro recorder	X	X

Options	cell ^M	cell ^R
Piezo-electric objective drive (all microscopes) or nosepiece drive (IX51, IX71, IX81 only)	X	X
TIRFM lasers and illumination combiners, multi-line	X	X
FRET, hardware and analysis (different algorithms)	X	X
Deconvolution for resolution enhancement	X	X
3-D rendering for three-dimensional image generation	X	X
Particle detection and tracking	X	X

Upgradeability	to cell ^R

System Diagram

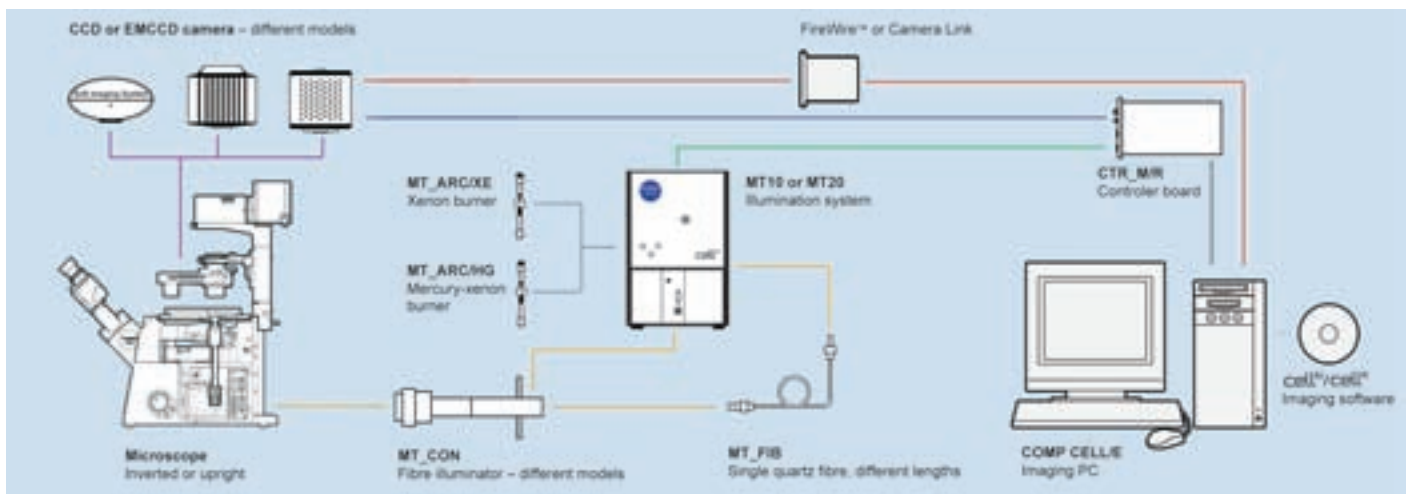

Specifications are subject to change without any obligation on the part of the manufacturer.

www.olympus-europa.com

OLYMPUS

OLYMPUS LIFE SCIENCE EUROPA GMBH

Postfach 10 49 08, 20034 Hamburg, Germany
 Wendenstraße 14-18, 20097 Hamburg, Germany
 Phone: +49 40 23 77 30, Fax: +49 40 23 77 36 47
 E-mail: microscopy@olympus-europa.com