

**OLYMPUS**<sup>®</sup>

Your Vision, Our Future

SEMICONDUCTOR/FPD/INDUSTRIAL  
INSPECTION MICROSCOPE

**MX61/MX61L/MX51**

**UIS2**  
World-leading optics



The best way to the best results

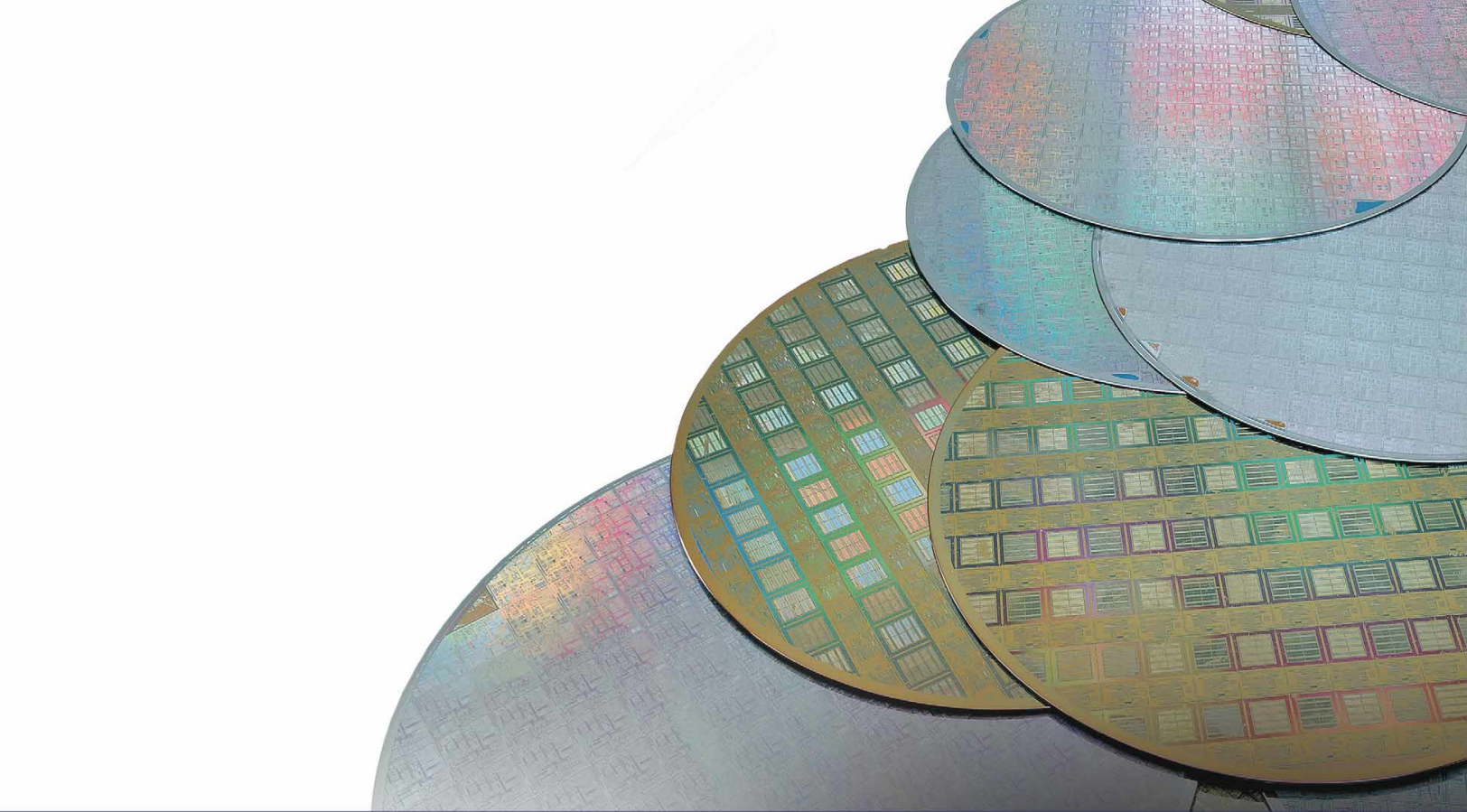

The highest efficiency...for all our

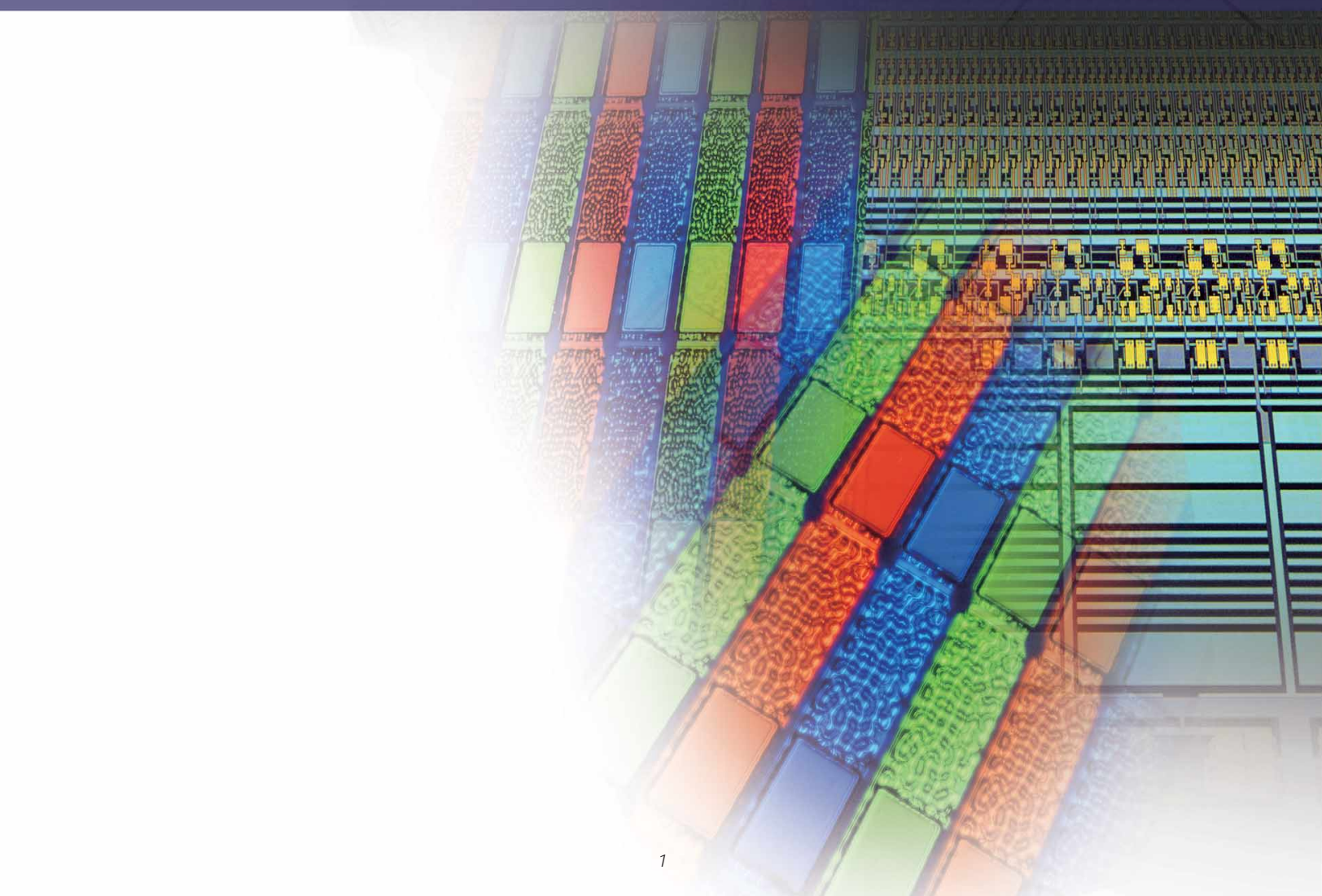



Olympus' key priority is the needs of each individual customer.

Naturally, we aim to ensure that our inspection microscopes deliver maximum benefit from the time of selection right through to after-sales support. And with our long experience of the industry, we already provide many clear-cut solutions to making electronic device inspections easier, quicker and more efficient.

At the same time, we know that each customer is unique, and has to address a unique set of issues to successfully incorporate the microscope into the production process. That's why we are always ready to help, at an individual, local level, providing ideas, solutions and support tailored to specific application needs.

Moreover, we incorporate our latest UIS2 infinity-corrected optical system by further evolving the performance of the inspection/industrial microscopes.

The highest efficiency for all our customers — that's the commitment underlying the development of our MX61/61L/MX51.

## customers



**MX61**  
SEMICONDUCTOR  
INSPECTION MICROSCOPE



**MX51**  
INDUSTRIAL  
INSPECTION MICROSCOPE



**MX61L**  
300 mm SEMICONDUCTOR/FPD  
INSPECTION MICROSCOPE

Olympus MX microscopes benefit every customer right from the start — meeting their needs in full, without wasting time or money.

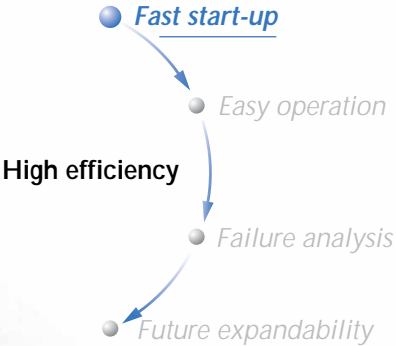

**Front-mounted main controls for faster, more efficient operations.**

The adjustment of AS (Aperture Stop) open/close, which plays a key role in determining image contrast, is synchronized with objective lens exchange and observation method, and controlled by buttons. Inspection efficiency is further improved by the front-panel location of the light adjustment, which can be operated by a single finger. The buttons for objective lens exchange and AS are positioned crosswise for easy operation with the thumb only, so that the user does not have to let go of the focusing handle. The crosswise button layout also enhances fingertip sensitivity and prevents operating mistakes.



① Reflected light adjustment dial  
② Objective lens magnifications exchange buttons  
③ AS open/close buttons

**Tilting trinocular tubes to suit any viewing posture.**

Adjusting chair height or adopting an unnatural posture to suit the operator's eyepoint are just two of the many small inconveniences that can slow down working speed. With this in mind, the MX61/61L is equipped with a tilting tube whose tilt angle can be varied from 0° to 42° (variable height: 150 mm, compatible with SEMI S8); this allows operators to find their most comfortable posture, regardless of physical differences, and also enables inspection while standing. The tube also features a long distance from the center of the observation axis to the eyepoint, so that even a large stage can be operated easily.

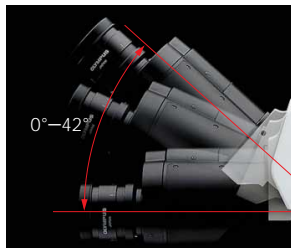

**SEMI S2/S8 compliance ensures safety and reliability.**

The MX61/61L comply in full with international specifications and standards such as SEMI S2/S8, CE, and UL, and respond to environmental and safety issues with a high level of reliability.

**Clean Class 1 conformity: numerous features to exclude dust.**

All driving components are housed in a shielded structure and are made of materials that offer excellent abrasion resistance and conformity with Clean Class 1. (There is a separate Class 1 compatible model for use with a revolving nosepiece.) MX61 is capable of accommodating up to 200 mm wafers and MX61L up to 300 mm wafers with the same small footprint. The depth of the 300 mm wafer compatible system is amazingly small, occupying just 537 mm on the table, or 677 mm to the end of the lamp housing.

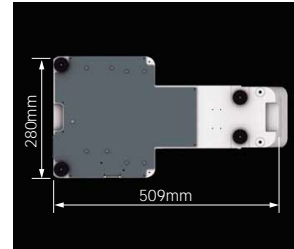

MX61/MX61L occupy small footprint area

**Optimized construction materials with upgraded anti-static protection.**

Antistatic processing is applied to the microscope frame, tube, breath shield and other parts, to prevent wafer contamination.



Antistatic breath shield

**Safe, quick wafer handling improves product throughput.**

A wafer loader can be attached to both MX61/61L models with no significant increase in overall footprint size. Safe, efficient operation, from back macro to micro inspections, can be performed without using tweezers. The wafer cassette can easily be set from the front side.



MX61 combined with AL110 wafer loader (200 mm version)



Speedy detection of any flaw ensures faster, more productive throughput.

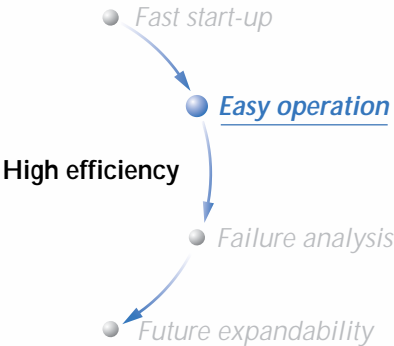

**Simultaneous AS (Aperture Stop) adjustment and objective lens switching obtains optimal contrast instantly, making inspections much faster.**

Inspections are slowed down if AS adjustment has to be performed manually every time the objective lens is changed. But with the MX61/61L, users can preset AS in 14 steps for each level of objective lens power, ensuring optimal image contrast immediately whenever the objective lens power or the observation mode is changed. This eliminates the time and effort spent on AS adjustment, reduces operator fatigue and speeds up the inspection process.

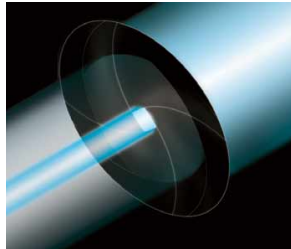

Powered aperture diaphragm

**Easy switching and addition of observation methods.**

Both MX61/MX61L microscopes offer quick selection of observation mode via a single lever—brightfield, darkfield and optional cube. And newly launched MPLFLN (-BD) series objective lenses require no positional switching of the prism from 5x to 150x in DIC observation. A transmitted light illumination unit can also be combined with both microscope stands, to enable the transmitted light polarizing observation required for FPD inspections.



Observation method selection

**Two high-precision stages for faster sample positioning.**

Two stages are available: the MX-SIC1412R2, which complies with wafers up to 300 mm and a 17-inch panel, and the MX-SIC8R which complies with wafers up to 200 mm. The former provides a larger Y transmitted light illumination area (284 mm) than the previous model (increased by 55 mm in the Y-axis). In addition, the stage grip has a built-in clutch, to allow exchange between fine and coarse movement while retaining the grip on the handle: this enables unrestricted stage movement while observing through the eyepiece, and facilitates faster inspections.



Quick operation of stage grip with built-in clutch

**Faster objective lens exchange.**

The motorized nosepiece revolves 20% faster than previous models, and objective lens exchange (low-high/high-low magnification) is button operated, enabling faster inspection speeds. Users can select from among 3 clean-type revolving nosepieces, according to need. Furthermore, centration tolerance about high magnification UIS2 objective lenses\* on the microscope nosepiece greatly improved so that the central images always keep within the center of the field of view even in observation using a CCD camera with a small-sized image sensor.



\*50x or higher magnification for both the MPLFLN series and LMPLFLN series.

**Various holders for different sizes of sample.**

Users can select various types of 8"-6" and 8"-12"\* wafer-sized wafer holders, mask holders, and glass plates. As a result, the production line can be modified at minimal cost even when the object of inspection changes. With the MX61, different stages can be used to accommodate 3", 4", 5" and 6" wafers on the inspection line. \*MX61L only



- ①MX-WHPR128    ②MX-SPG128
- ③BH3-SPG6    ④MX-WHPR86
- ⑤BH2-WHR65    ⑥BH2-WHR54
- ⑦BH2-WHR43
- ⑤-⑦: Need to combine with BH3-WHP6



High resolving power and high image sensitivity support faster, more accurate analysis.

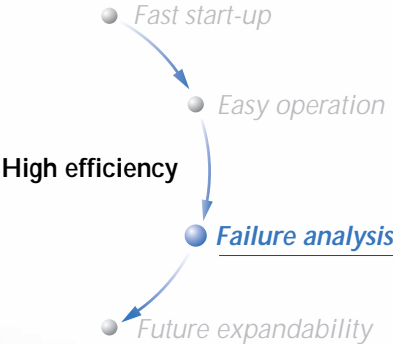



**Advanced optical performance delivers a remarkable improvement in defect detection.**

The UIS2, further advanced optical system, delivers finer observation images; clear, high-contrast brightfield images with optimized color temperature, which capture color tone differences with outstanding precision as well. Also, newly designed Plan SemiApochromatic series objective lenses with improved detection capability achieve the highest detection precision in darkfield observation\*, and enables quick detection of minute scratches that would previously have been overlooked.

\*Combined with recommended objective lenses and compared with our conventional model

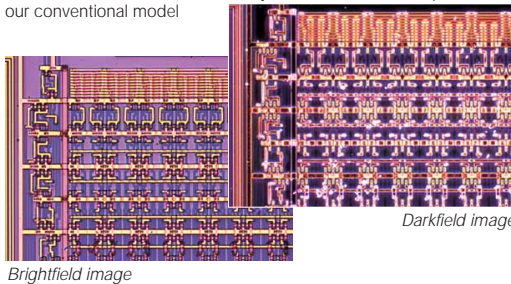

Brightfield image

Darkfield image

**Optimized DIC contrast for different surface conditions enhances defect detection.**

Three kinds of DIC prism — standard, high contrast or high resolution — can be selected according to the surface irregularities and reflection characteristics of the samples. This delivers images with optimized contrast and spatial effect, greatly improving defect detection ability.

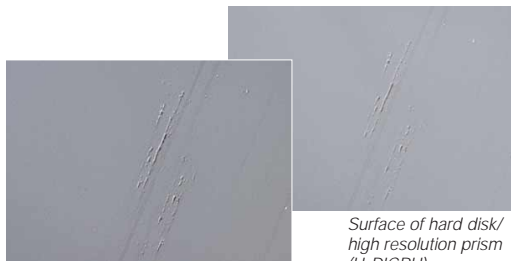

Surface of hard disk/  
High contrast prism (U-DICRH)

Surface of hard disk/  
high resolution prism  
(U-DICRH)

**Simultaneous use of reflected and transmitted light.**

Reflected light and (optional) transmitted light illumination systems can be used simultaneously, with independent intensity adjustment for each. This combination is ideal for precision inspections of semitranslucent devices.

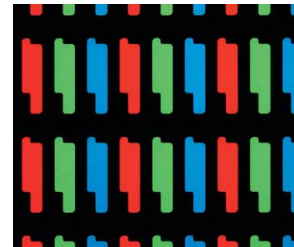

LCD panel/transmitted light image

**High N.A. and long working distance objective lenses improve operability.**

Different types of UIS2 objective lenses that combine high resolving power with long working distances are available. These objective lenses minimize direct contact with samples caused by inaccurate operation of the focusing knob, and deliver the clear, high-resolution images needed for more precise analysis. Special objective lenses designed for industrial-leading applications, e.g. LCD (Liquid Crystal Display) inspection, are also available.



LCD objective lenses  
(The new correction ring method provides adjustable glass thickness in 0 through 1.2 mm for 20x, 50x and 0 through 0.7 mm for 100x.)

**High performance imaging systems.**

A wide range of digital cameras can be attached to the various tilting trinocular tubes. Olympus also offers digital cameras equipped with software for controlling the MX Series via a communications interface in the microscope stand.

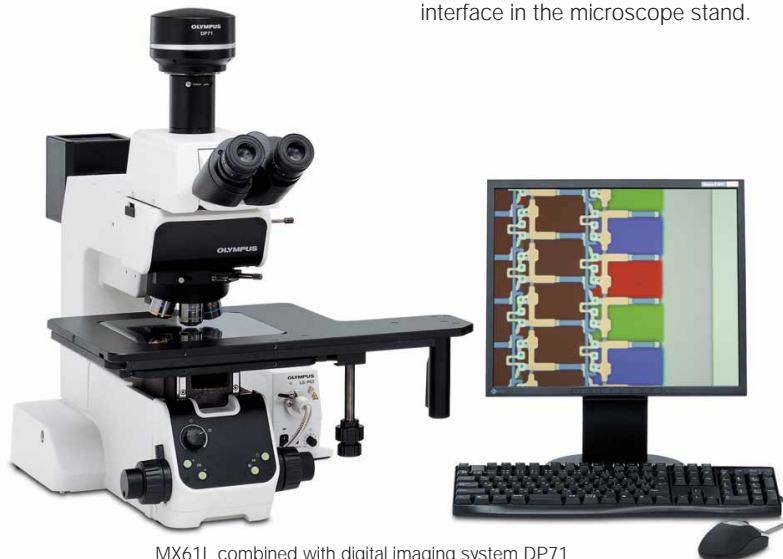

MX61L combined with digital imaging system DP71

A complete range of accessories, available when and if you need them — no other exclusive optical microscope required.

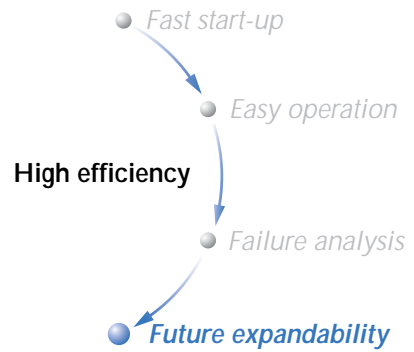

## DUV

**High-magnification and high-contrast DUV realtime observation.**

### Deep ultraviolet observation system for microscopes U-UVF248

The latest DUV optical design ensures the high-contrast images down to a resolution limit of 0.08  $\mu\text{m}$  with minimum flare. The system enables seamless observation from low magnification visible-light to DUV.

*\*DUV microscope system, exclusive catalog is also available.*



DUV observation

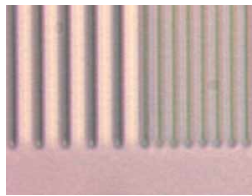

Visible-light observation

## IR

**Suitable for observing silicon wafers, the inside of compound wafers, and the bonding section of wafer bump.**

### Near Infrared (IR) modules

Compatible accessories include objective lenses which compensate for aberrations from the visible to near IR wavelength light and various other options, allowing comprehensive inspection of the bump wafer.

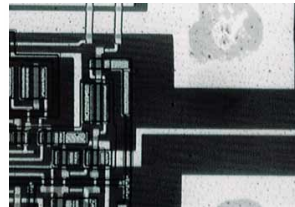

Bonding pad from the back side of wafer

## FL

**Suitable for judgement of resist residue.**

### Fluorescent modules

For fluorescence observation, a mirror unit can be added in the slider. U\*, B and G excitation mirror units are available; they are used for inspecting resist residue or organic LEDs.

*\*Since U excitation is applicable to some objectives, please contact Olympus representatives.*

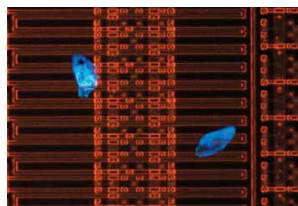

Particles on wafer (left)  
Fluorescence mirror units (far left)





## Transmitted Light Illumination

Indispensable for observing FPD or MEMS\* sensors.

### Transmitted illumination modules MX-TILLA/MX-TILLB

There are two types of illumination modules: one for general purpose use and the other with high N.A. (Numerical Aperture). These transmitted illumination modules are provided to enable inspections for photomask and FPD. A polarizer is also equipped, allowing simple polarizing observations using transmitted light.

\*Micro-Electro-Mechanical System

Control panel of MX-TILLB

- ① Insertion slot for fiber light guide
- ② Filter slot ③ Field Stop (F.S.) lever
- ④ Centering holes (2) for F.S.



## I/F

Controlling/obtaining information about microscope magnifications and aperture diaphragm.

### RS232C

An RS232C interface is equipped on the MX61/61L as standard, enabling various motorized parts of the microscope to be controlled via a PC. The observation conditions for several microscopes can be set in the same way; this makes it possible to establish such conditions on a uniform basis among several PCs; to replicate particular environmental conditions of use.



## Motorized Stage

Specific observation points on the wafer can be programmed, reducing tact time.

### Motorized stage (MS200)

This stage is used when the MX61/61L is used in combination with wafer loader AL110. This enables complete surface inspections of a 200 mm wafer, with specific inspection points quickly detected and examined according to preset programs.



MS200 (far right)  
Control of wafer loader  
AL110-8 (right)



# The MX51 Effect: More Efficient Inspections Throughout Industry.

( *Streamlined operation for faster, more comprehensive results* )

Quick, efficient inspections

High efficiency

Minimal-cost expandability

Practical versatility



## Agile stage movement and coarse/fine movement interchange.

Two stage sizes are available, 150 mm and 100 mm. The 150 mm stage has a built-in clutch lever, which enables quick location of specimens on the stage without diverting the operator's view, allowing quick, easy inspections.

## Repositioned optical controls for smoother performance.

Controls for focusing and light intensity adjustment are placed closer together, so that both can be operated with one and the same hand.



## Anti-static treatment prevents dust contaminating the sample.

The frame and 6-inch stage are coated to prevent static build-up.

\* Use special metal plate.

## SEMI S2/S8 compliance enhances safety and ergonomics.

The convenience of front operation is one of the Olympus' key design concepts, complemented by compliance with international industry standards to guarantee superior reliability.

## Motorized revolving nosepiece enables direct exchange of objective lenses for higher efficiency.

In addition to the standard nosepiece, the MX51 can be equipped with a range of motorized nosepieces. An external handset allows direct selection of the desired objective lens. The MX51 also offers a centerable, motorized nosepiece for accurate positioning for easy observation at high magnifications.





*Practical versatility: the MX51 is ideal for many different kinds of inspections*

#### Latest UIS2 optics maximize detection of even tiny defects.

Fast detection of defects and fewer check failures are ensured through brighter brightfield observation and darkfield observation, whose detection sensitivity has been improved over the entire series. Outstanding accuracy in observation of small diameter wafers such as those used in today's smaller sensors and many other high-performance electronic devices.

\*In the recommended set of objective lens and illuminator

#### Offers multiple observation methods from visible to fluorescence and near-IR.

The standard illuminator (BX-RLA2) complies with near IR observation, as well as offering brightfield, darkfield, Nomarski DIC and simple polarizing observations. A universal illuminator (BX-URA2) is also available for fluorescence observation. A deep ultraviolet observation system for microscopes\* can also be equipped.

\*For details, see P. 9.

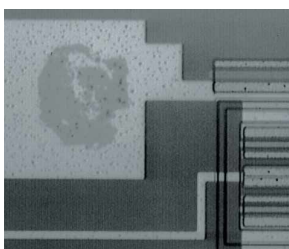

#### Transmitted light observation.

The combination of a transmitted illumination unit with the 150 mm stage enables transmitted light brightfield observation of samples up to 2 mm thick, with an illumination range of 100 x 100 mm. The slim-profiled illumination unit is designed for minimal effect on the stage operation and is useful for observations of samples such as MEMS (Micro Electronics Mechanical Systems) sensors and other optical/optronic components.



#### Intermediate attachment raises objective lenses to accommodate thick samples.

The standard maximum sample thickness is 30 mm. Insert the intermediate attachment to accommodate thicker samples.



*Expandability: adding extra functions at minimal cost*

#### Combine with wafers loaders to increase work efficiency.

Use of the AL110-6 series wafer loaders, which accept wafers up to 150 mm, offers front- and back-macro inspection and microscope inspection without the operator handling the wafers.



#### Confocal module for high-resolution, high contrast observations.

The confocal module (U-CFU) employs an original disk scanning method to deliver high-contrast, high-resolution observation images. This allows inspection of multi-layered electronic devices.

#### Digital imaging with excellent cost performance.

A wide range of cost-effective Olympus digital cameras can be added to the MX51. Additionally, adapters allow the use of digital or video cameras currently in use.



DP20 configuration

#### Accepts many high-quality BX2M accessories.

A wide range of the highly-regarded BX2M series accessories can be used, including a tilting observation tube, motorized illuminator, various lamp housings, motorized revolving nosepieces, mirror units, prisms, filters and intermediate attachments.

# Accessories

## Observation tubes



- ①MX-SWETTR Super widefield erect image tilting trinocular observation tube
- ②U-SWETTR-5 Super widefield erect image tilting trinocular observation tube
- ③U-TR30-2 Trinocular tube ④U-SWTR-3 Super widefield trinocular tube
- ⑤U-BI30-2 Binocular tube ⑥U-ETR4 Erect image trinocular tube

## Reflected light illuminators for MX51



- ①BX-URA2 Universal reflected light illuminator
- ②BX-RLAA Motorized BF/DF reflected light illuminator
- ③BX-RLA2 Reflected light illuminator for BF/DF
- ④BX-KMA Reflected light illuminator for BF (U-LS30-4 30W lamp socket included)

## Revolving nosepieces for MX51



- ①U-D7RE Septuple revolving nosepiece with slider slot for DIC
- ②U-D6BDRE Sextuple BD revolving nosepiece with slider slot for DIC
- ③U-P5BDRE Centerable quintuple BD revolving nosepiece with slider slot for DIC
- ④U-D6RE Sextuple revolving nosepiece with slider slot for DIC
- ⑤U-D5BDRE Quintuple BD revolving nosepiece with slider slot for DIC

## Motorized revolving nosepieces



- ①U-D5BDREMC Motorized quintuple BD revolving nosepiece with slider slot for DIC
- ②U-D6REMC Motorized sextuple revolving nosepiece with slider slot for DIC
- ③U-D6BDREMC Motorized sextuple BD revolving nosepiece with slider slot for DIC
- ④U-P5BDREMC Motorized centerable quintuple BD revolving nosepiece with slider slot for DIC

## Lamphousings



- ①U-LH100HG 100W mercury lamphousing
- ②U-LH100HGAPO 100W mercury apo lamphousing
- ③U-LH100-3/U-LH100L-3 100W halogen lamphousing
- ④U-LH75XEAP0 75W xenon apo lamphousing

## Stage accessories for MX51

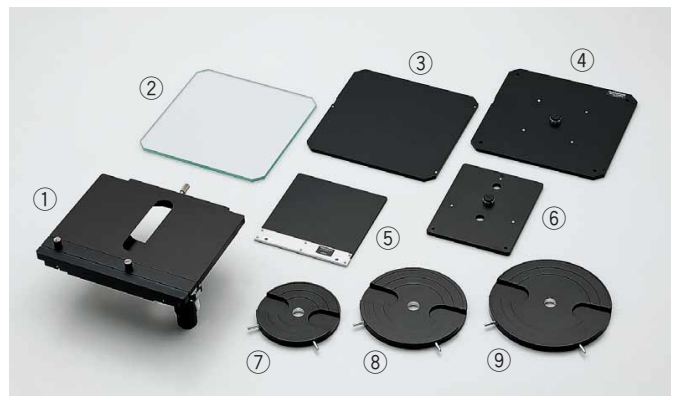

- ①U-SIC4R2/L2 Right/left hand control large-size stages (should be combined with stage adapter MX-STAD, photo shown is U-SIC4R2)
- ②BH3-SPG6 Stage glass plate
- ③BH3-SP6 6" stage plate
- ④BH3-WHP6 6" stage plate (Can be combined with BH2-WHR43/54/65)
- ⑤U-MSSP4 Stage plate
- ⑥U-WHP2 Plate (Can be combined with BH2-WHR43 for U-SIC4R2/L2)
- ⑦BH2-WHR43 4"-3" rotatable wafer holder
- ⑧BH2-WHR54 5"-4" rotatable wafer holder
- ⑨BH2-WHR65 6"-5" rotatable wafer holder



# Objective lenses



## MPLFLN (-BD) Plan SemiAchromat series

These Plan SemiAchromat objective lenses completely eliminate chromatic aberration at high level, which is perfect for a wide range of microscopic methods including brightfield darkfield, fluorescence, Nomarski DIC and simple polarized observation. Since exit pupil positions from 5x through 150x are standardized, no switching of the DIC prism lever position is necessary when the objective lens power changes. Use the BD series in brightfield and darkfield observation.

\* High contrast images are obtained at 1.25x or 2.5x observation combining with both analyzer (U-AN360-3) and polarizer (U-DICAF2 for MX61, U-PO3 for MX51)



## MPLFLN-BD Plan SemiAchromat series

The Plan SemiAchromat POL is the Universal objective lens that become the best choice for Nomarski DIC microscopy.



## LMPLFLN (-BD) Plan SemiAchromat series

The LMPLFLN (-BD) series provides more free space between the objective lens and the specimen than other Plan SemiAchromatic objective lens series so that it can prevent from collision between objective lens with the stepped specimen. Since exit pupil positions from 5x through 100x are standardized, no switching of the DIC prism lever position is necessary when the objective lens power changes. Use the BD series in brightfield and darkfield observation.



## MPLN (-BD) Plan Achromat series

Plan Achromat objective lenses with excellent flatness up to F.N. 22. Use the BD series in brightfield and darkfield observation.

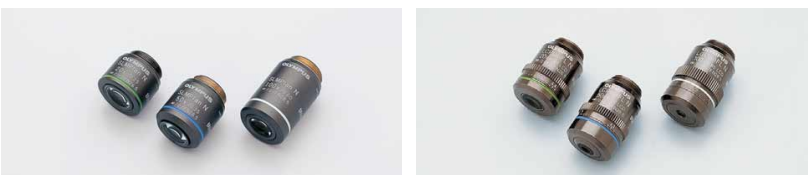

## SLMPLN series

This Ultra long working distance series minimizes a risk of collision between the specimen and the objective lens and it also delivers high contrast imaging.



## MPlanAPO (-BD) Plan Achromat series

Plan Achromat objective lenses with optimal chromatic aberration correction.



## LCPLFLN-LCD series

The perfect objective lenses for imaging specimen through glass plate like an LCD application. Aberration correction matched to the glass thickness is possible by using a correction ring.



## LMPlan-IR, MPlan-IR series

Plan Achromat objective lenses which compensate for aberrations from visible to near infrared light.

Objective lenses	Magnifications	N.A.	W.D. (mm)	Cover Glass Thickness (mm)	Resolution*2 (μm)
MPLFLN	1.25x*3*5	0.04	3.5	–	8.39
	2.5x*5	0.08	10.7	–	4.19
	5x	0.15	20.0	–	2.24
	10x	0.30	11.0	–	1.12
	20x	0.45	3.1	0	0.75
	50x	0.80	1.0	0	0.42
MPLFLN-BD*4	100x	0.90	1.0	0	0.37
	5x	0.15	12.0	–	2.24
	10x	0.30	6.5	–	1.12
	20x	0.45	3.0	0	0.75
	50x	0.80	1.0	0	0.42
	100x	0.90	1.0	0	0.37
MPLFLN-BDP*4	150x	0.90	1.0	0	0.37
	5x	0.15	12.0	–	2.24
	10x	0.25	6.5	–	1.34
	20x	0.40	3.0	0	0.84
	50x	0.75	1.0	0	0.45
	100x	0.90	1.0	0	0.37
LMPLFLN	5x	0.13	22.5	–	2.58
	10x	0.25	21.0	–	1.34
	20x	0.40	12.0	0	0.84
	50x	0.50	10.6	0	0.67
	100x	0.80	3.4	0	0.42
	LMPLFLN-BD*4	5x	0.13	15.0	–
10x		0.25	10.0	–	1.34
20x		0.40	12.0	0	0.84
50x		0.50	10.6	0	0.67
100x		0.80	3.3	0	0.42
MPLN*3		5x	0.10	20.0	–
	10x	0.25	10.6	–	1.34
	20x	0.40	1.3	0	0.84
	50x	0.75	0.38	0	0.45
	100x	0.90	0.21	0	0.37
	MPLN-BD*1*3*4	5x	0.10	12.0	–
10x		0.25	6.5	–	1.34
20x		0.40	1.3	0	0.84
50x		0.75	0.38	0	0.45
100x		0.90	0.21	0	0.37
SLMPLN		20x	0.25	25	–
	50x	0.35	18	0	0.96
	100x	0.6	7.6	0	0.56
LCPLFLN-LCD	20x	0.45	8.3 - 7.4	0 - 1.2	0.75
	50x	0.70	3.0 - 2.2	0 - 1.2	0.48
	100x	0.85	1.2 - 0.9	0 - 0.7	0.39



Objective lenses	Magnifications	N.A.	W.D. (mm)	Cover Glass Thickness (mm)	Resolution*2 (μm)
MPlanApo	50x	0.95	0.3	0	0.35
	100x	0.95	0.35	0	0.35
	100xOil	1.40	0.1	0	0.24
MPlanApo-BD	100x	0.90	0.31	0	0.37
LMPlan-IR	5x	0.10	20.0	–	–
	10x	0.25	18.5	–	–
	20x	0.40	8.1	–	–
	50x	0.55	6.0	–	–
	100x	0.80	3.4	–	–
MPlan-IR*3	100x	0.95	0.3	–	–

\* "BD" = "Brightfield/darkfield" objective lenses

\*1 Slight vignetting may occur in the periphery of the field when MPLN-BD series objective lenses are used with high-intensity light sources such as mercury and xenon for darkfield observation.

\*2 Resolutions calculated with aperture iris diaphragm wide open.

\*3 Limited up to F.N. 22. No compliance with F.N. 26.5.

\*4 BD objective lenses cannot be combined with BX41M-ESD.

\*5 Analyzer and polarizer are recommended to the usage with MPLFLN1.25x or 2.5x.

■MX61/61L System Diagram

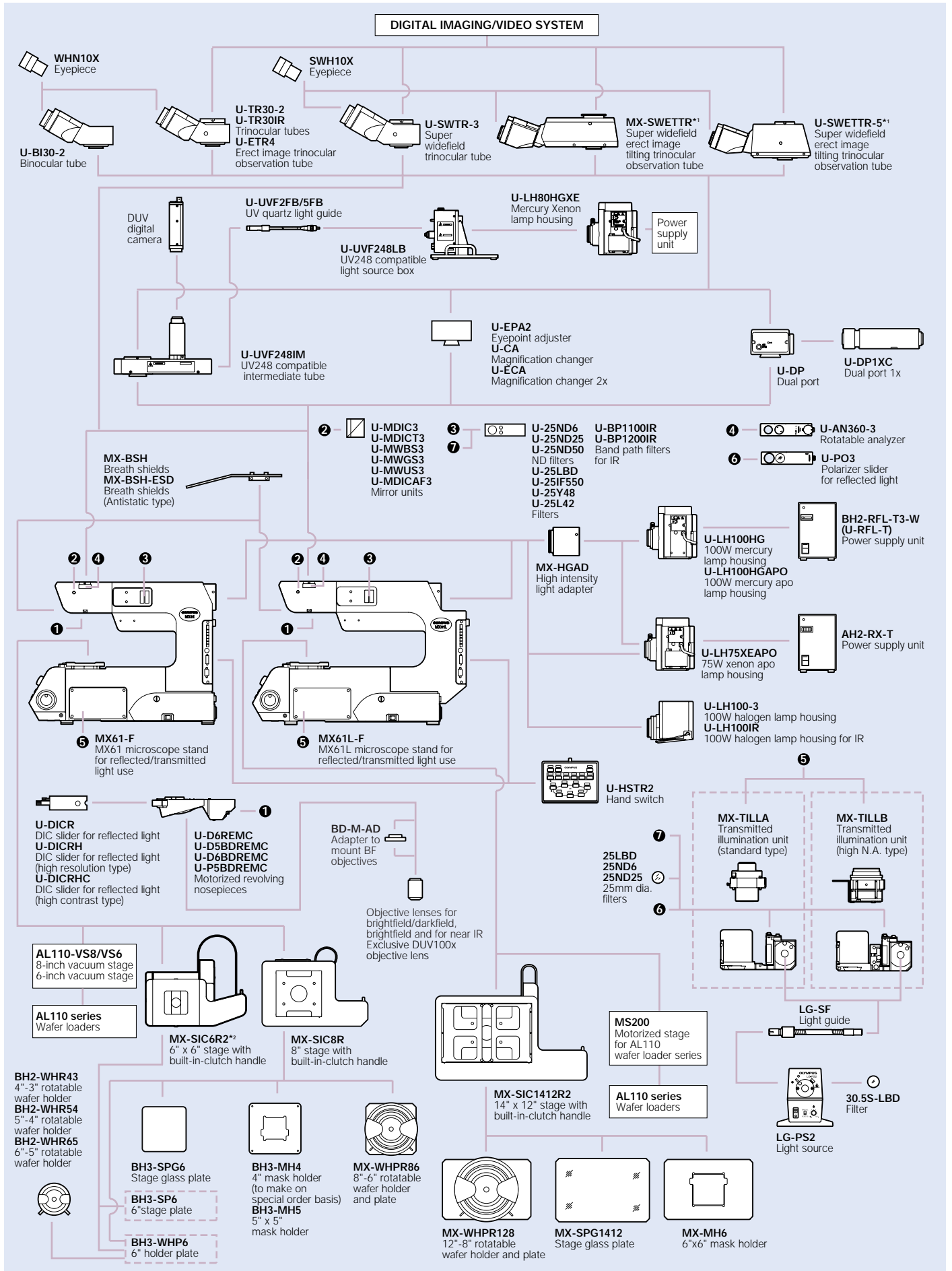

\*1 MX61L can be combined with MX-SWETTR or U-SWETTR-5 \*2 Reflected light use only

# MX51 System Diagram

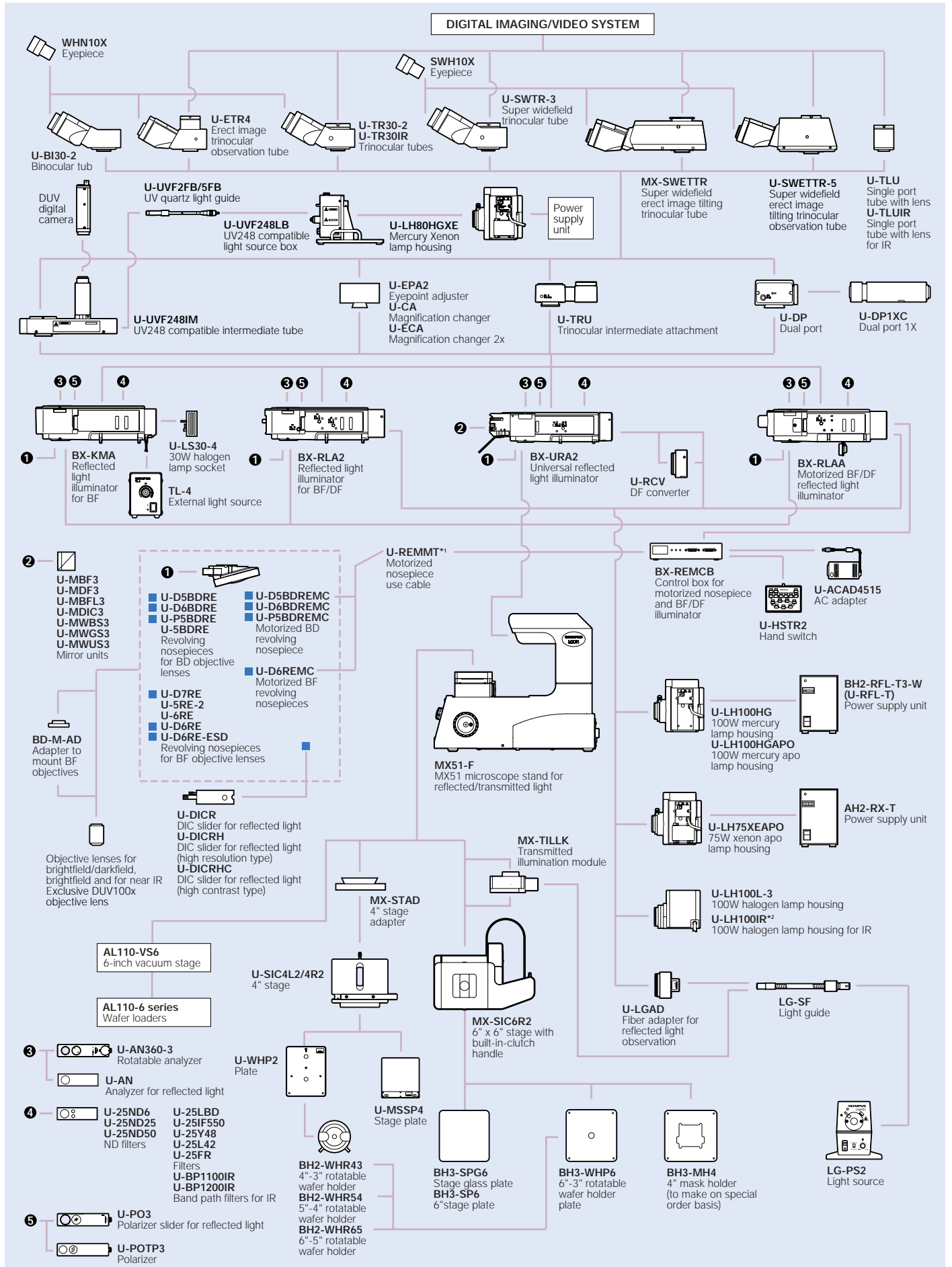

\*1 For other illuminations than BX-RLAA \*2 Extended cable U-RMT is needed



## ■MX61/MX61L specifications

Model	MX61	MX61L
Optical system	UIS2 optical system (infinity-corrected system)	
Microscope stand	<b>Reflected light illumination (F.N. 26.5)</b> 12V, 100W halogen lamp (pre-centering type) Brightfield/darkfield mirror plus 1 cube (option), exchange method Built-in motorized aperture diaphragm (Pre-setting for each objective lens, automatically open for darkfield observation) <b>Transmitted light illumination* (F.N. 26.5)</b> *When transmitted illumination unit MX-TILLA or MX-TILLB is combined. Illumination by light source LG-PS2 and light guide LG-SF (12V,100W halogen lamp) or their equivalent. •MX-TILLA: condenser (N.A.0.5), with aperture stop •MX-TILLB: condenser (N.A.0.6), with aperture stop and field stop <b>Observation methods</b> ①Reflected light brightfield ②Reflected light darkfield ③Reflected light Nomarski DIC ④Reflected light simple polarizing ⑤Reflected light fluorescence ⑥Reflected light IR ⑦Transmitted light brightfield ⑧Transmitted light simple polarizing *Separate (optional) cubes are required for ③, ④ and ⑤. *⑦ and ⑧ require combination with a transmitted illumination unit.	
Observation tube	Super widefield erect image tilting trinocular tube (F.N.26.5): MX-SWETTR or U-SWETTR-5 Others: Super widefield trinocular tube/Widefield binocular tube	Super widefield erect image tilting trinocular tube (F.N.26.5): MX-SWETTR or U-SWETTR-5
Revolving nosepiece	Motorized sextuple revolving nosepiece with slider slot for DIC: U-D6REMC Motorized quintuple BD revolving nosepiece with slider slot for DIC: U-D5BDREMC Motorized sextuple BD revolving nosepiece with slider slot for DIC: U-D6BDREMC Motorized centerable quintuple BD revolving nosepiece with slider slot for DIC: U-P5BDREMC Forward rotation by objective lens exchange button on the front panel of microscope, or directly by hand switch U-HSTR2 (user designation)	
Stage	MX-SIC8R 8" x 8" stage Stroke: 210 x 210 mm (Transmitted light illumination area: 189 x 189mm) MX-SIC6R2 6" x 6" stage Stroke: 158 x 158 mm (Reflected light use only with MX61)	MX-SIC1412R2 14" x 12" stage Stroke: 356 x 305 mm (Transmitted light illumination area: 356 x 284 mm) combination with MX-TILLB
	Roller guide slide mechanism, belt drive system (no rack), grip clutch function (belt drive disengagement system)	
Power consumption	Built-in reflected light source body 100-120/220-240V~1.9/0.9A 50/60Hz, Transmitted light source (LG-PS2) 100-120/220-240V~3.0/1.8A 50/60Hz	
Dimensions/weight	Dimensions: approx. 509(W) x 843(D) x 507(H) mm Weight: approx. 40 kg (microscope stand only approx. 27kg)	Dimensions: approx. 710(W) x 843(D) x 507(H) mm Weight: approx. 51kg (microscope stand only approx. 31 kg)

## ■MX51 specifications

Optical system	UIS2 optical system (infinity-corrected system)		
Microscope stand	2-guide rack and pinion method Coarse and fine coaxial Z-axis control stroke 32mm (2mm upper and 30mm below from the focal plane) The same stroke 15mm (combination with transmitted illumination) Stroke per rotation of fine Z-axis control 0.1 mm (1 unit 1μm) Coarse handle torque adjustment Coarse handle upper limit lever		
Illumination	BX-KMA Brightfield illuminator	BX-RLA2 Brightfield/Darkfield illuminator	BX-URA2 Universal Fluorescence illuminator
	Contrast changeover method — Applicable observation mode ① Brightfield ② Normaski DIC ③ Polarized light	BF-DF slide method ① Brightfield ② Darkfield ③ Normaski DIC ④ Polarized light ⑤ IR	Mirror unit (Max. up to 6) turret method ① Brightfield ② Darkfield ③ Normaski DIC ④ Polarized light ⑤ Fluorescence
Lamphousing	6V30W Halogen Lamp socket: U-LS30-4 Transformer: TL-4	12V100W Halogen Lamphouse: U-LH100L-3 Power supply is integrated in MX51	Mercury lamp house: U-LH100HGAP0 External power supply BH2-RFL-T3 needed
Transmitted illumination	Brightfield MX-TILLK combined with fiber light guide illumination (configured with MX-SIC6R2)		
Power supply unit	—	Rated voltage: 100-120/220-240V~1.8A/0.8A 50/60Hz Continuous light intensity dial	
Observation tube	U-BI30-2 Widefield binocular, U-TR30-2 Widefield trinocular, U-ETR4 Widefield erect image trinocular (F.N. 22), U-SWTR-3 Super widefield trinocular, MX-SWETTR/U-SWETTR-5 Super widefield erect image tilting trinocular (F.N. 26.5)		
Revolving nosepiece	U-5RE-2, U-6RE U-D5BDRE, U-D6BDRE, U-P5BDRE (with slider slot for DIC Prism)		
Stage	U-SIC4R2/SIC4L2 Coaxial right/left-hand control 4" x 4" stage	MX-SIC6R2 Coaxial right-hand control 6" x 6" stage	
	Drive method: rack and pinion method Y axis stopper: lever method	Drive method: Belt method Stroke: 158(X) x158 (Y) mm Clutch method: 2 clutch plates (Built-in-clutch ON/OFF handle) Holder dimensions: 200 x 200 mm Transmitted light area: 100 x 100 mm	
Dimensions/weight	Dimensions: Approx. 430(W) x 591(D) x 495(H) mm Weight: Approx. 26 kg (Stand Approx. 11kg)		

■ Dimensions (unit: mm)

MX61

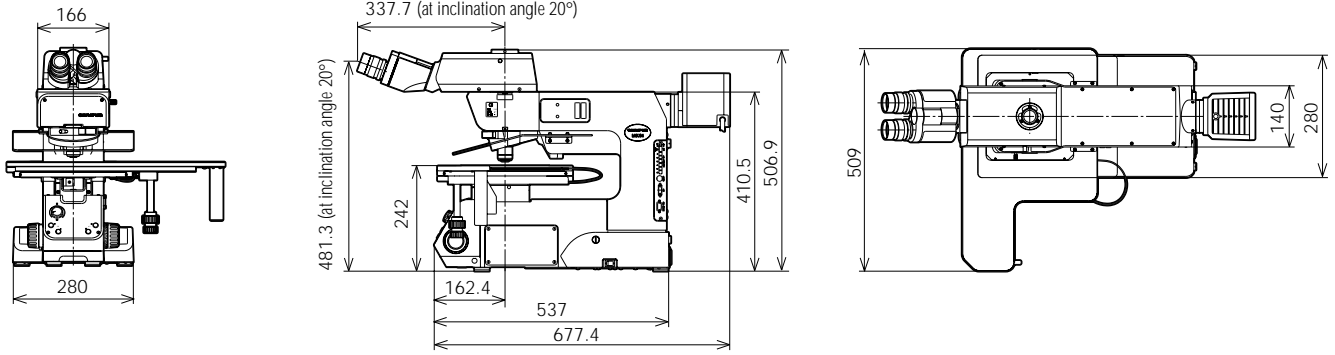

MX61L

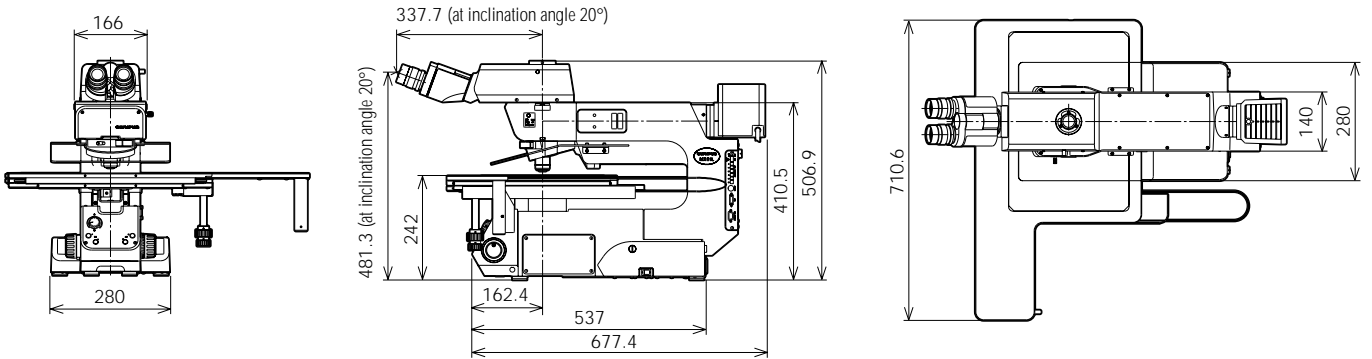

MX51

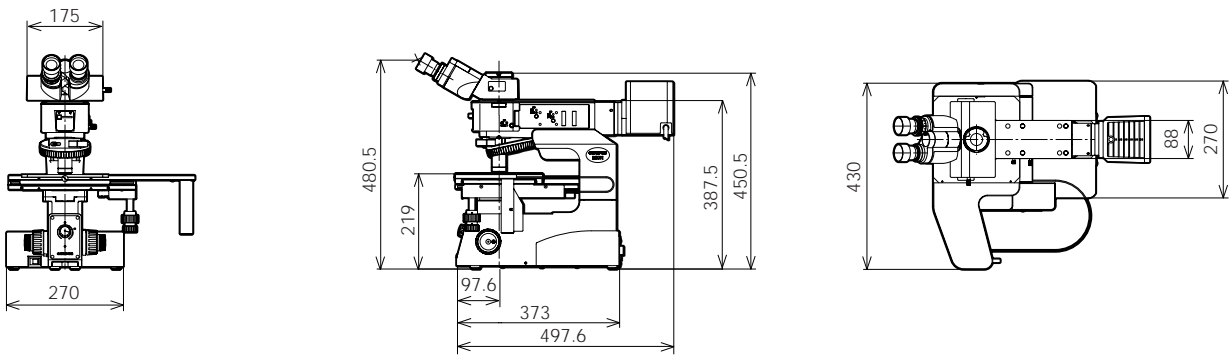

MX61+AL110-86

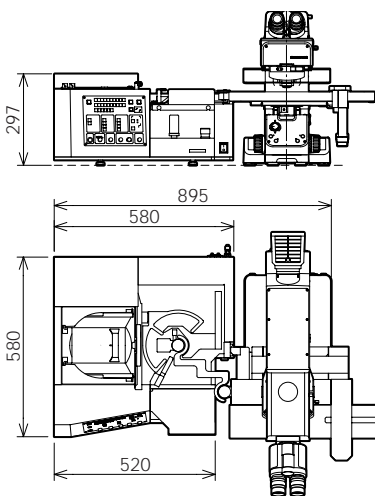

MX61+AL110-6

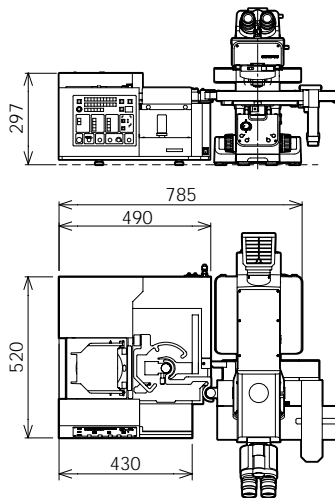

MX51+AL110-6

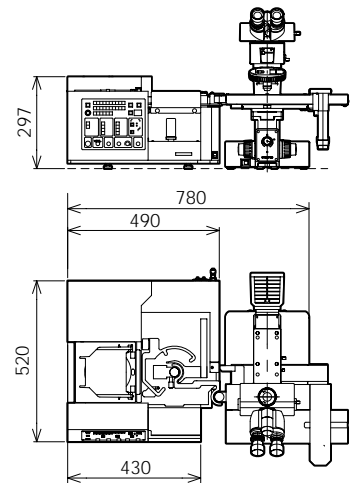

•OLYMPUS CORPORATION has obtained ISO9001/ISO14001.

Specifications are subject to change without any obligation on the part of the manufacturer.

---

**OLYMPUS**<sup>®</sup>

**OLYMPUS CORPORATION**  
Shinjuku Monolith, 3-1, Nishi Shinjuku 2-chome, Shinjuku-ku, Tokyo, Japan  
**OLYMPUS LIFE SCIENCE EUROPA GMBH**  
Postfach 10 49 08, 20034, Hamburg, Germany  
**OLYMPUS SURGICAL & INDUSTRIAL AMERICA INC.**  
One Corporate Drive, Orangeburg, NY 10962, U.S.A.  
**OLYMPUS UK LTD.**  
2-8 Honduras Street, London EC1Y 0TX, United Kingdom.

**OLYMPUS AUSTRALIA PTY. LTD.**  
31 Gilby Road, Mt. Waverley, VIC 3149, Melbourne, Australia.  
**OLYMPUS LATIN AMERICA, INC.**  
5301 Blue Lagoon Drive, Suite 290 Miami, FL 33126, U.S.A.

[www.olympus.com](http://www.olympus.com)

Printed in Japan M1633E-0907B